

8 7 6 5 4 3 2 1

F
E
D
C
B
A

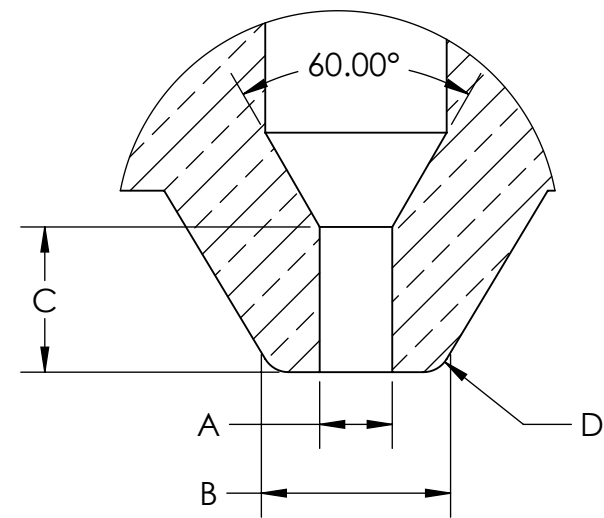
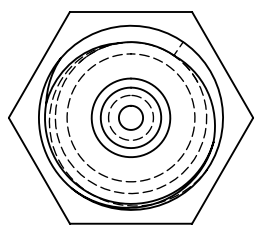

DETAIL B
SCALE 12 : 1

Table 1				
OPT	A	B	C	D
25	0.25	0.63	0.38	0.10
35	0.30	0.75	0.45	0.10
35	0.35	0.88	0.53	0.15
40	0.40	1.00	0.60	0.20
50	0.50	1.25	0.90	0.20
60	0.60	1.50	1.20	0.25
80	0.80	2.00	1.60	0.30

Var/C/181006/ZZX

Table 2	
Type	Description
1	Brass
2	Titanium T4
3	Hardened Steel

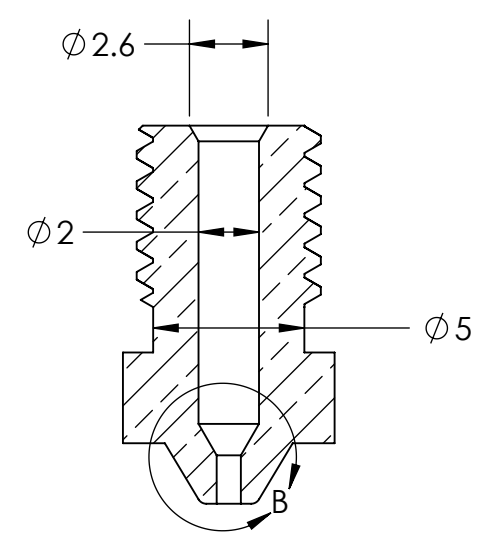
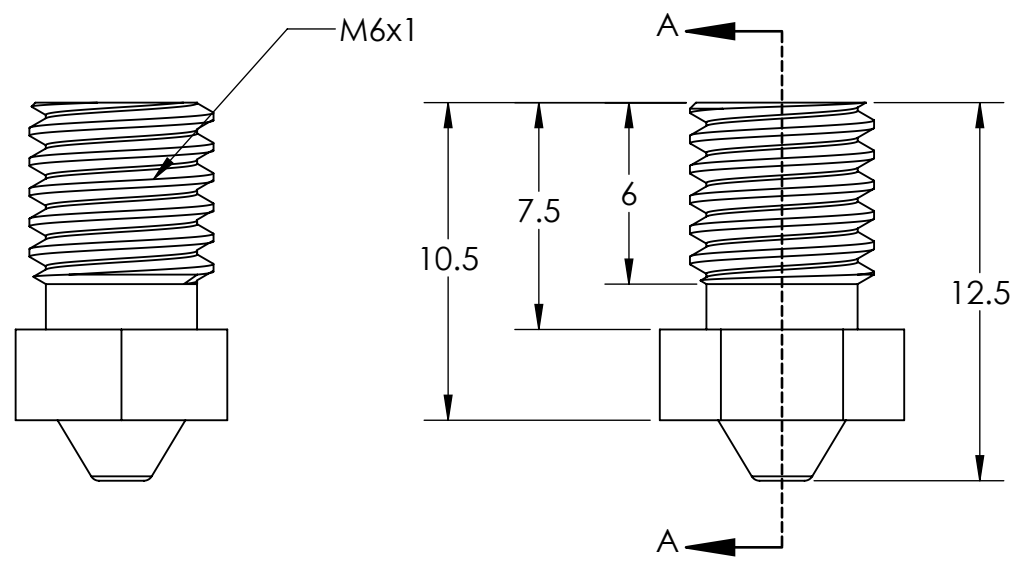

SECTION A-A

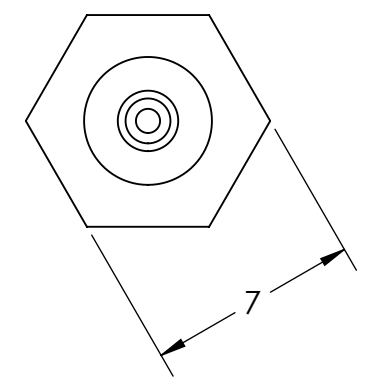
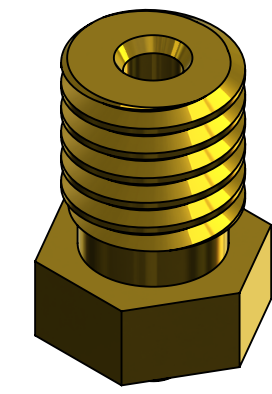

All Dimensions are in mm
Material : See Table 2
Surface Finish: Unfinished Unless Stated

OWNER/ COMPANY INFO.				UNLESS OTHERWISE SPECIFIED: DIMENSIONS ARE IN MILLIMETERS		TITLE:	
 Mfg. Process: Machining/ CNC Machining				TOLERANCE: ANGULAR: MACH ±0.5 DEG		V6 compatible Nozzle	
				TWO PLACE DECIMAL ±0.25			
DRAWN BY: Sobug				DEBURR AND BREAK SHARP EDGES		DWG NO. Var/C/181006/000	
CHK'D & APPV'D BY: Richard				FINISH: UNFINISHED UNLESS STATED			
DATE: 13/08/2018				MATERIAL: See Notes		A3	
WEIGHT (gm): 2.43				Qty.: 1 pcs		REVISION A	
SCALE: 4:1				SHEET 1 OF 1			

8 7 6 5 4 3 2 1